

Chapter 6/7 – Properties of Polygons

1. Tell if the measures can be the side lengths of a triangle.
 - a. 9, 12, 16
 - b. 11, 14, 27

2. Use the diagrams below to answer the questions.
 - a. List the sides in order from shortest to longest.

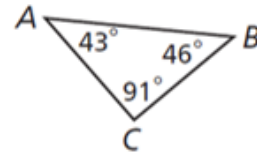

- b. List the angles in order from smallest to largest

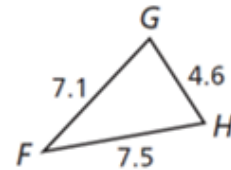

3. Find the sum of the interior angle measures of a convex dodecagon.

4. Find the measure of EACH interior angle of a regular pentagon

5. Find the measure of b in figure FGHL. Then, find the measure of angle LFG.

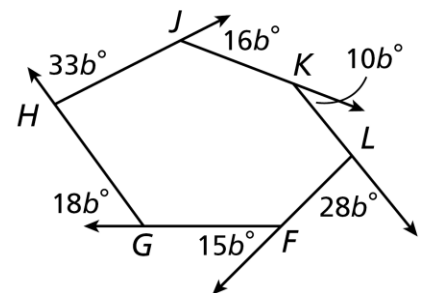

6. In rhombus $WXYZ$, $WX = 25$ and $WY = 48$.
- Find XZ

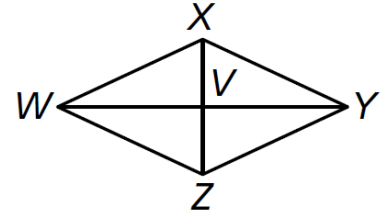

- Find the area of the rhombus.

7. Find the measure of angle C in parallelogram $ACEG$.

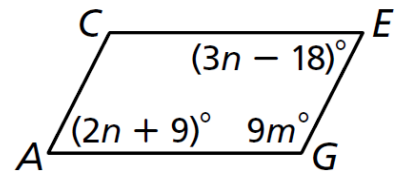

8. Solve for the measure of each angle in the shape.

$$m\angle 1 =$$

$$m\angle 2 =$$

$$m\angle 3 =$$

$$m\angle 4 =$$

$$m\angle 5 =$$

rectangle $MNPQ$

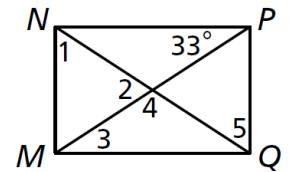

9. Find $m\angle R$ and $m\angle S$.

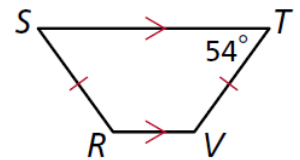

Chapter 8/9 – Special Triangles and Trigonometry

10. Use special right triangles to find the missing variable in each triangle.

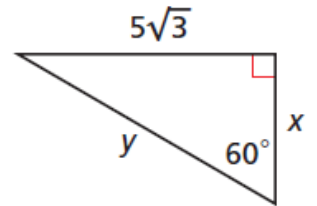
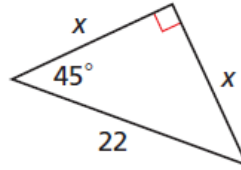
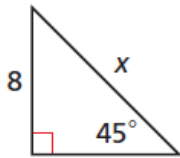

11. A 10-foot ladder is leaned up against a wall. The base of the ladder is 5 feet away from the wall. How high up on the wall is the ladder? Round your answer to the nearest tenth.

12. Write the fraction that represents each trigonometric ratio.

$\tan R =$

$\cos R =$

$\sin R =$

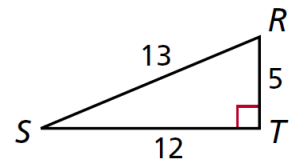

13. Find each missing value. Round your answer to the nearest tenth.

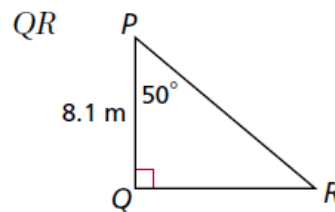
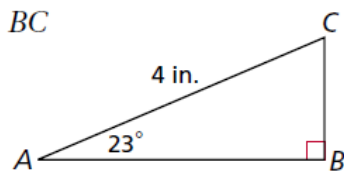

14. Find the measure of angle R.

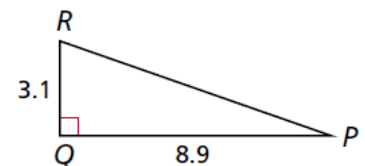

15. Find the measure of the missing angle.

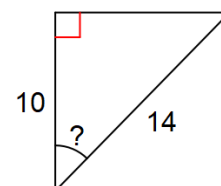

16. A telephone pole is supported by steel cables as shown in the figure. If the phone company were planning on installing another cable on the other side 17 feet from the pole, how much total steel cable is used for **both** of the steel cables combined? Round your answer to the nearest tenth.



17. A ramp is leaned on a porch that is 1.5 feet off the ground. If the angle a ramp makes with the ground is 14.5° , find the length of the ramp to the nearest tenth of a foot.

18. A 25 foot tall light pole casts a shadow on the ground that is 37 feet long. What is the angle of elevation from the end of the shadow to the top of the light pole? Round your answer to the nearest tenth.

19. The two triangles are similar. Find the value of x .

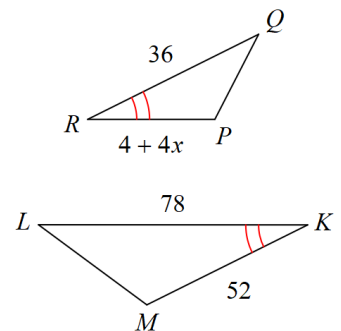

Chapter 10 – Circles

20. Find the value of r .

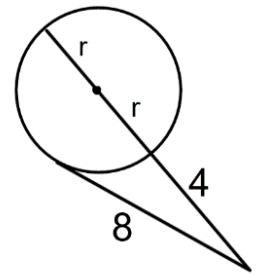

21. Using the figure to the right:

a. Solve for x .

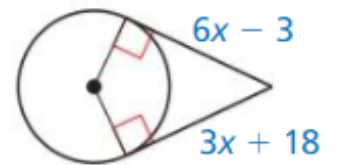

22. Q is the center of the circle. Find the length of chord ST .

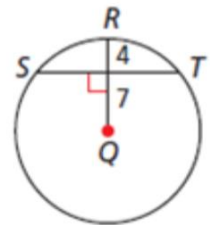

23. Find each of the following:

a. $m\widehat{JL}$

b. $m\angle MKL$

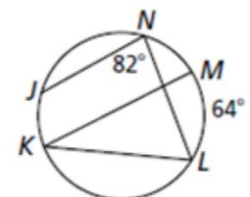

24. Find $m\angle RSP$.

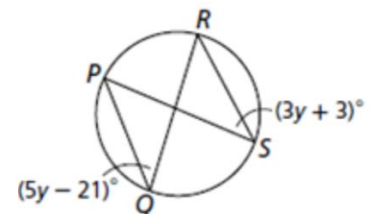

25. Solve for y .

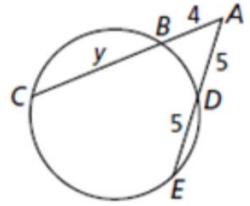

26. Solve for y .

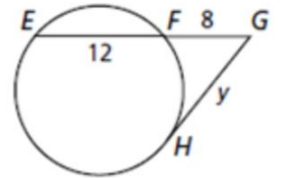

27. Write the equation for the circle in each graph below:

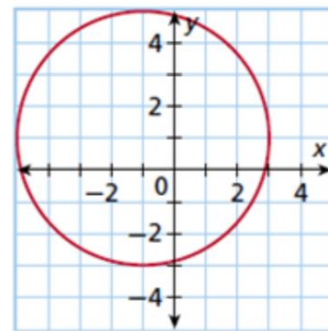
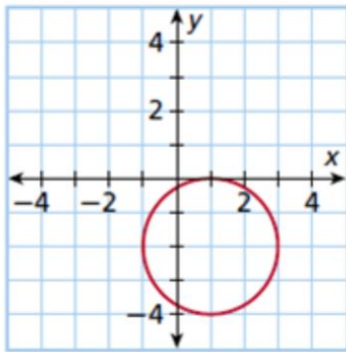

28. Write the equation of a circle that:

a. Passes through $(2, 2)$ and has a center at $(1, 1)$.

b. Passes through $(-5, 1)$ and has a center at $(1, -2)$.

Chapter 11 – Circles, Surface Area, and Volume

29. Find the volume of the figure.

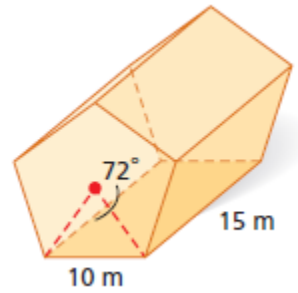

30. Find the volume of the composite figure.

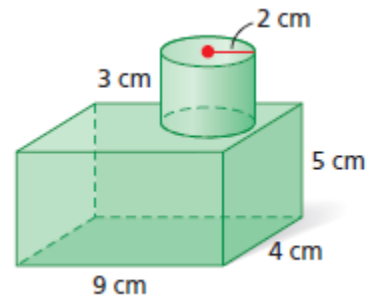

31. Find the volume and surface area of the figure.

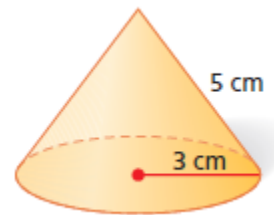

32. Find the volume and surface area of the figure.

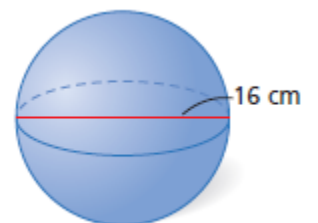

33. Find the volume of the hexagonal pyramid.

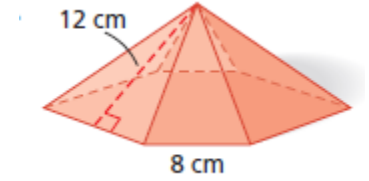

34. Find the area of the sector AND the length of the arc intercepted by the radii.

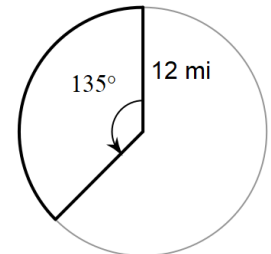

35. Find the area of the sector AND the length of the arc intercepted by the radii.

